



# CIRCUIT PROTECTION WITH NON-LINEAR RESISTORS

PTC and NTC Thermistors, Through-Hole Varistors

RESISTIVE PRODUCTS

CAPABILITIES

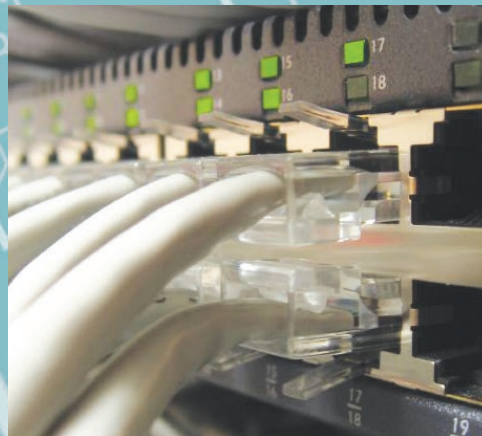

## Using PTC – Positive Temperature Coefficient Thermistors

The electrical resistance of ceramic PTC (positive temperature coefficient) thermistors increases exponentially at the so called switching temperature or  $T_s$ . This typical characteristic makes PTC thermistors very useful components for several application areas such as voltage and current overload protection, over-temperature protection, inrush current generation, time delay, energy discharge, and as a ceramic self-limiting heating element. As an overload protective element, PTC thermistors are used in a wide range of circuits, including line cards, set-top boxes, and private automated branch exchanges in telecom applications; airbag and temperature control devices in automobiles; power supplies, transformers, DC motors and small domestic appliances; and in other consumer products.

## PTC Overload Protection Principles

### Features

- Different voltages in function of the application: 30 V to 60 V, 145 V, 265 V, 600 V
- Several mechanical executions: pellets, through hole leaded, SMD
- Wide range of trip and hold currents: from 10 mA to 4.5 A minimum trip currents
- Wide range of resistance: from 0.3  $\Omega$  to 5 k $\Omega$
- Small ratio between trip and hold currents ( $I_{trip}/I_{hold} = 1.5$  at 25 °C)
- High maximum inrush current: up to 30 A
- UL approved series

### Part Numbers

General overload protection:

- 30 V to 60 V series: PTCLL..H....BE series (UL approved)
- 145 V series: PTCLL..H...FBE (UL approved)
- 265 V series: PTCLL..H...HBE (UL approved)
- 600 V series: PTCLL..H...SBE
- SMD series: PTCTZ

Over-temperature:

- $T_n$  70 °C to 140 °C: PTCSS Series (SMD, UL approved)
- $T_n$  70 °C to 150 °C: PTCSL Series

Telecom protection:

- General leaded: PTCTL
- SMD: PTCTZ and PTCTT

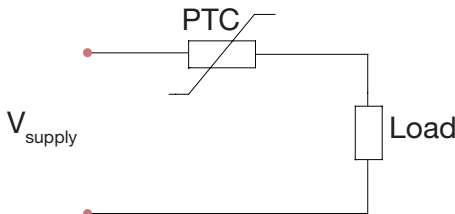

Figure 1

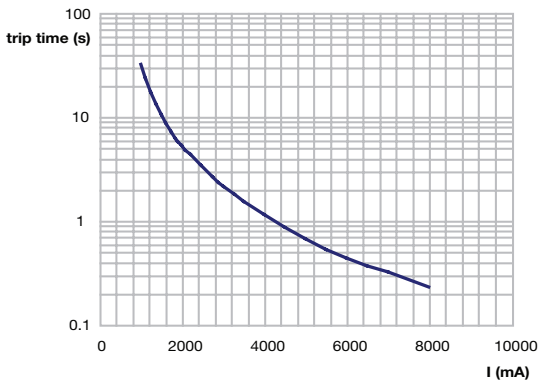

Figure 3

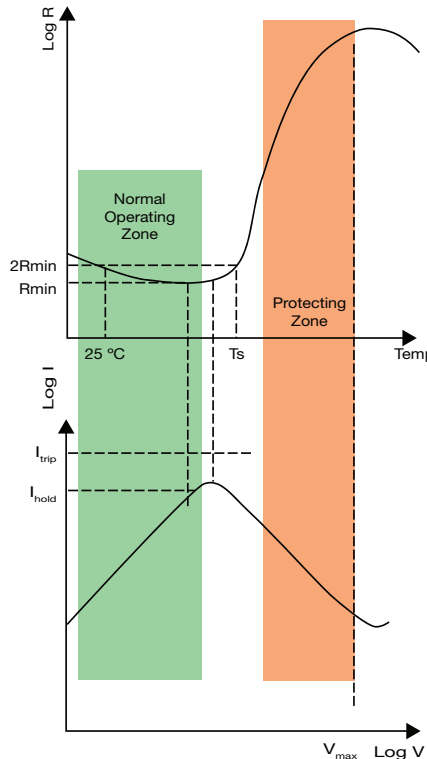

Figure 2

When connected in series with the input of an electrical or electronic circuit load (see Figure 1), such as a small motor or power supply, the PTC thermistor acts as a self-resettable fuse, protecting the circuit against current, voltage and temperature overload conditions.

In normal operating conditions the PTC resistance is low (see Figure 2), and the current is below its hold value ( $I_{hold}$ ). However, an overload will quickly heat up the PTC thermistor until, at around the switching temperature ( $T_s$ ), its resistance increases rapidly, limiting the current to far below its trip value ( $I_{trip}$ ), and so protecting the circuit. The trip time until protection will depend on the level of overload (see Figure 3).

## Using NTC – Negative Temperature Coefficient Thermistors

The electrical resistance of NTC (negative temperature coefficient) thermistors increases as the ambient temperature decreases, and decreases when temperature increases. NTC thermistors are used for overtemperature protection in PCs, power supplies, and motherboards; Li-ion battery protection in fast chargers; and in digital scan cameras, fire and smoke detectors, TCXOs, and other automotive, consumer, and industrial applications. They are generally included in a voltage divider or Wheatstone bridges and can provide a measuring voltage to analog-digital converters. They also allow to control the temperature compensation of displays and regulation of temperature with opamps or more complex ICs.

### Features for Circuit Protection:

- Led and SMD versions in case sizes from 0402 to 1206
- Large resistance range: from 3.3  $\Omega$  to 470 k $\Omega$
- Temperature range: – 55  $^{\circ}\text{C}$  to + 155  $^{\circ}\text{C}$
- SMD termination: 100 % Sn over Nickel
- Customized types available upon request

## Examples of NTC Circuit Protection

### PC Cooling Fan

The output  $\bar{Q}$  of a bistable RS drives the gate of a MOSFET transistor switching a cooling fan on and off.

The cooling principle is based on a limit cycle regulation between a chosen low temperature  $T_{low}$  (the NTC value at temperature  $T_{low}$  is equal to  $R_{low}$ ) and a high temperature  $T_{high}$  (the NTC value at  $T_{high}$  is equal to  $R_{high}$ ). The NTC value is compared to fixed resistors of values  $R_{low}$  and  $R_{high}$ . Input R and S depend directly upon this comparison. The cooler fan will work between the moment when R or S go from 0 to 1.

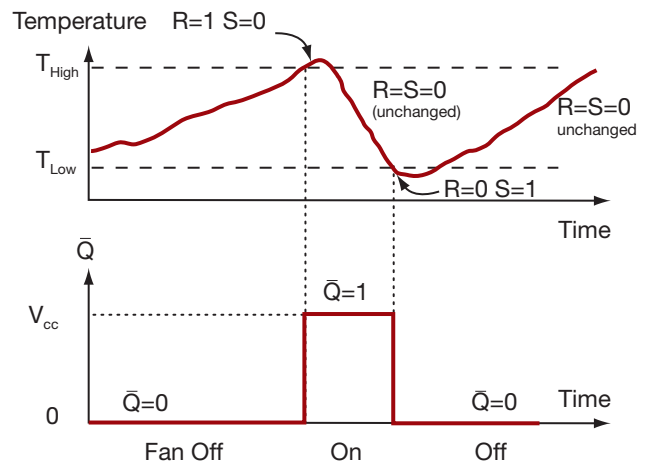
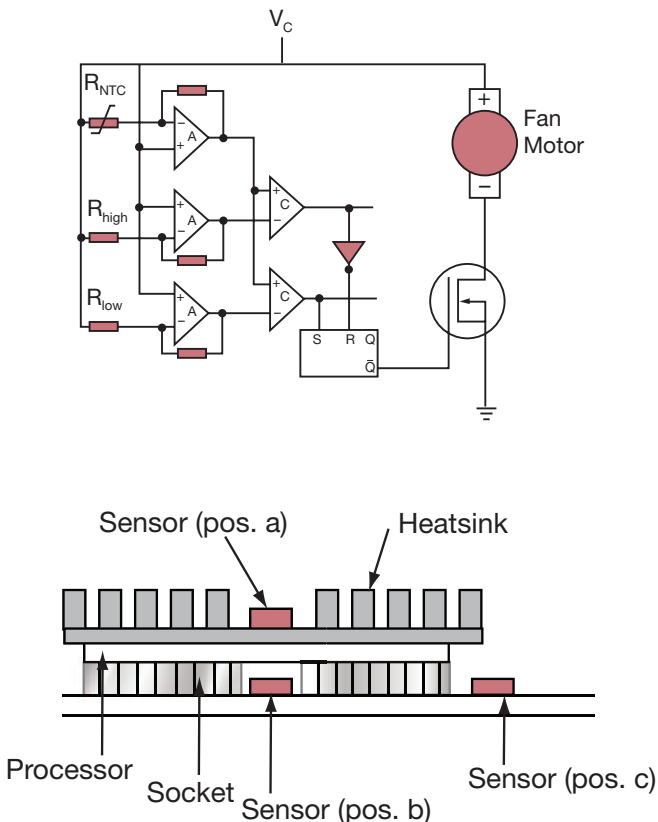



# CIRCUIT PROTECTION WITH NON-LINEAR RESISTORS

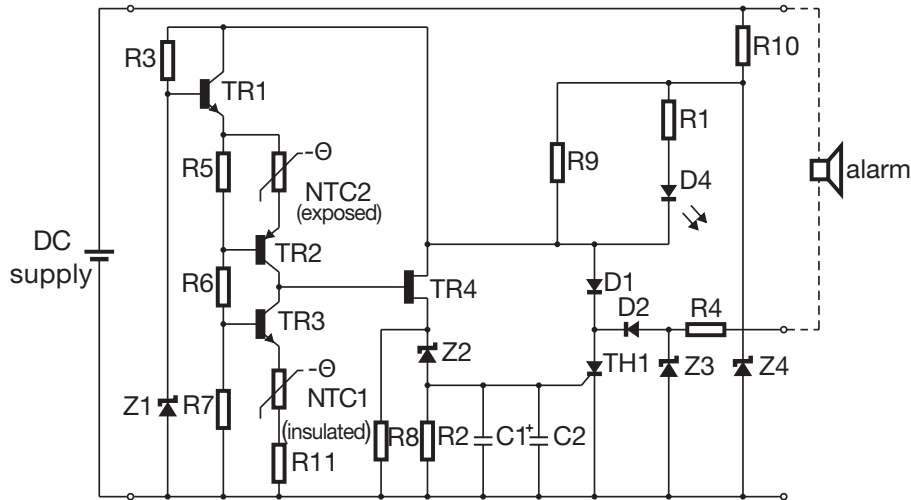

## Rate of Rise Heat Detecting Fire Alarm

Rate of rise heat detecting fire alarms operate on the principle of monitoring for a sudden rise in temperature associated with an outbreak of fire, rather than waiting for the temperature to increase to a predetermined fixed limit before activating. They therefore provide a faster response to a fire incident. The detector employs two matched NTC thermistors ( $NTC_1$  and  $NTC_2$ ), one of which is semi-protected in the body of the fire-alarm unit, while the other is exposed to the surrounding atmosphere. With a gradual rise and fall in ambient temperature, both sensors track each other fairly closely. With the outbreak of fire however, the exposed thermistor will react to the temperature increase faster than the shielded sensor. This causes an imbalance between the two sensors which in turn triggers the detector output. These detectors also feature an upper temperature limit at which point the detector will respond regardless of rise time.

## Using Through-Hole Varistors

VDRs (voltage dependent resistors), or Metal Oxide Varistors (MOV), are used for transient surge suppression. Surge suppression circuits are commonly used in computers, automobiles, telecom and industrial equipment, domestic appliances, and other consumer products.

### Specifications Table

Standard Series: VDRS05 to VDRS20		
Sizes from 5 mm to 20 mm	$V_{rms}$ from 14 V to 680 V $V_{dc}$ from 18 V to 895 V	Can absorb surges up to 6,500 A UL recognized according UL1449 edition3
High-Surge Series: VDRH05 to VDRH20		
Sizes from 5 mm to 20 mm	$V_{rms}$ from 11 V to 680 V $V_{dc}$ from 14 V to 895 V	Can absorb surges up to 10,000 A UL recognized according UL1449 edition3

### Example of VDR Circuit Protection in PC

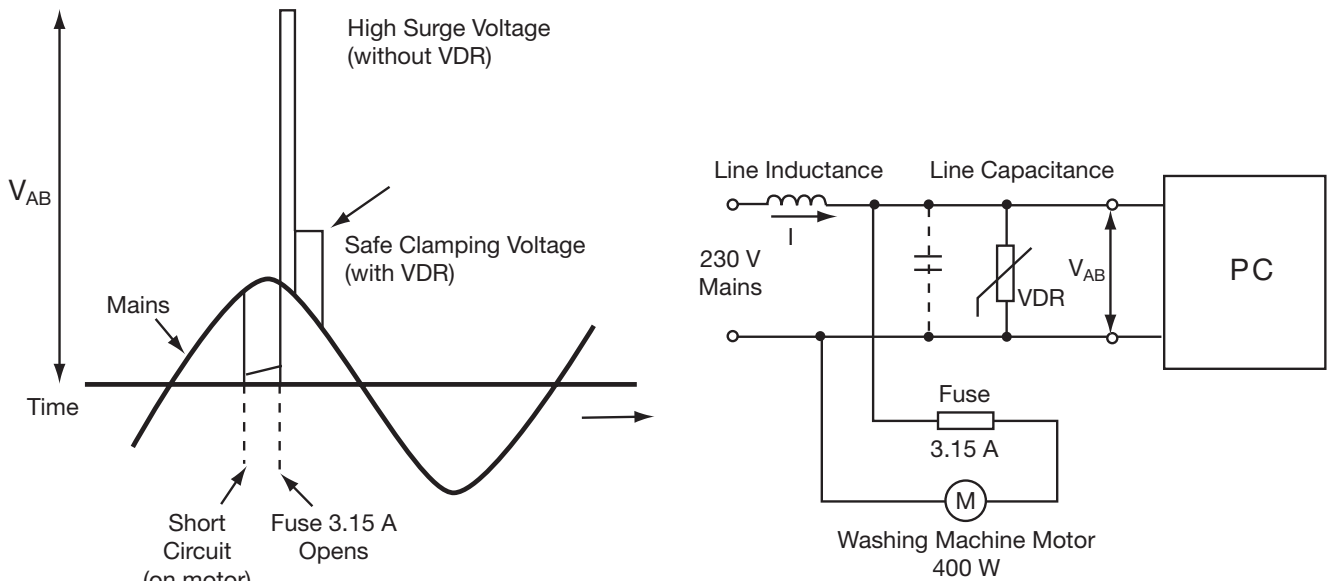



# CIRCUIT PROTECTION WITH NON-LINEAR RESISTORS

---

## Notes



## Notes

**DISCLAIMER** All product specifications and data are subject to change without notice. Vishay Intertechnology, Inc., its affiliates, agents, and employees, and all persons acting on its or their behalf (collectively, "Vishay"), disclaim any and all liability for any errors, inaccuracies or incompleteness contained herein or in any other disclosure relating to any product. Vishay disclaims any and all liability arising out of the use or application of any product described herein or of any information provided herein to the maximum extent permitted by law. The product specifications do not expand or otherwise modify Vishay's terms and conditions of purchase, including but not limited to the warranty expressed therein, which apply to these products. No license, express or implied, by estoppel or otherwise, to any intellectual property rights is granted by this document or by any conduct of Vishay. The products shown herein are not designed for use in medical, life-saving, or life-sustaining applications unless otherwise expressly indicated. Customers using or selling Vishay products not expressly indicated for use in such applications do so entirely at their own risk and agree to fully indemnify Vishay for any damages arising or resulting from such use or sale. Please contact authorized Vishay personnel to obtain written terms and conditions regarding products designed for such applications. Product names and markings noted herein may be trademarks of their respective owners.

## SEMICONDUCTORS:

Rectifiers • High-Power Diodes and Thyristors • Small-Signal Diodes • Zener and Suppressor Diodes  
• FETs • Optoelectronics • ICs • Modules

## PASSIVE COMPONENTS:

Resistive Products • Magnetics • Capacitors



One of the World's Largest Manufacturers of  
**Discrete Semiconductors and Passive Components**

## WORLDWIDE SALES CONTACTS

### THE AMERICAS

#### UNITED STATES

VISHAY AMERICAS  
ONE GREENWICH PLACE  
SHELTON, CT 06484  
UNITED STATES  
PH: +1-402-563-6866  
FAX: +1-402-563-6296

### ASIA

#### SINGAPORE

VISHAY INTERTECHNOLOGY ASIA PTE LTD.  
37A TAMPINES STREET 92 #07-00  
SINGAPORE 528886  
PH: +65-6788-6668  
FAX: +65-6788-0988

#### P.R. CHINA

VISHAY CHINA CO., LTD.  
15D, SUN TONG INFOPORT PLAZA  
55 HUAI HAI WEST ROAD  
SHANGHAI 200030  
P.R. CHINA  
PH: +86-21-5258 5000  
FAX: +86-21-5258 7979

#### JAPAN

VISHAY JAPAN CO., LTD.  
SHIBUYA PRESTIGE BLDG. 4F  
3-12-22, SHIBUYA  
SHIBUYA-KU  
TOKYO 150-0002  
JAPAN  
PH: +81-3-5466-7150  
FAX: +81-3-5466-7160

### EUROPE

#### GERMANY

VISHAY ELECTRONIC GMBH  
GEHEIMRAT-ROSENTHAL-STR. 100  
95100 SELB  
GERMANY  
PH: +49-9287-71-0  
FAX: +49-9287-70435

#### FRANCE

VISHAY S.A.  
199, BLVD DE LA MADELEINE  
06003 NICE, CEDEX 1  
FRANCE  
PH: +33-4-9337-2727  
FAX: +33-4-9337-2726

#### UNITED KINGDOM

VISHAY LTD.  
SUITE 6C, TOWER HOUSE  
ST. CATHERINE'S COURT  
SUNDERLAND ENTERPRISE PARK  
SUNDERLAND SR5 3XJ  
UNITED KINGDOM  
PH: +44-191-516-8584  
FAX: +44-191-549-9556

Build **Vishay**  
into your **Design**

[www.vishay.com](http://www.vishay.com)

VMN-PL0436-1009